

LOW VOLTAGE 256K (32K x 8) VERY FAST SRAM WITH OUTPUT ENABLE

- LOW VOLTAGE: 3.3V ± 0.3V
- 32K x 8 VERY FAST SRAM with OUTPUT ENABLE
- EQUAL CYCLE and ACCESS TIMES: 12, 15, 20ns
- LOW V_{CC} DATA RETENTION: 2V
- TRI-STATE COMMON I/O
- JEDEC PLASTIC SOJ 300 mil PACKAGE

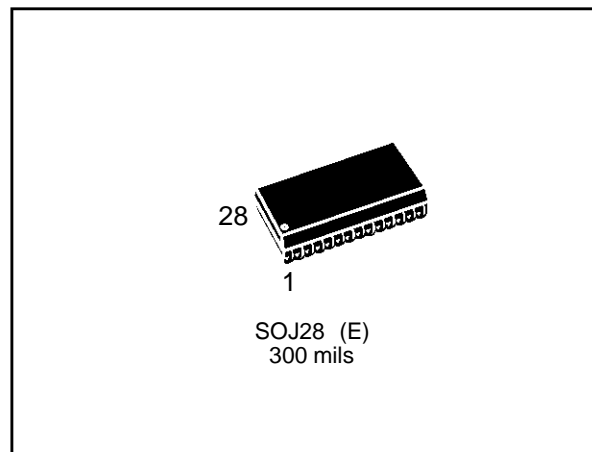

DESCRIPTION

The M638032 is a 256K (262,144 bit) Fast CMOS SRAM, organized as 32,768 words by 8 bits. It is fabricated using SGS-THOMSON's Advanced, low power, high performance, CMOS technology. The device features fully static operation requiring no external clocks or timing strobes, with equal address access and cycle times. It requires a single 3.3V ± 0.3V supply, and all inputs and outputs are TTL compatible.

Table 1. Signal Names

A0 - A14	Address Inputs
DQ0 - DQ7	Data Inputs / Outputs
\bar{E}	Chip Enable
\bar{G}	Output Enable
\bar{W}	Write Enable
V _{CC}	Supply Voltage
V _{SS}	Ground

Figure 1. Logic Diagram

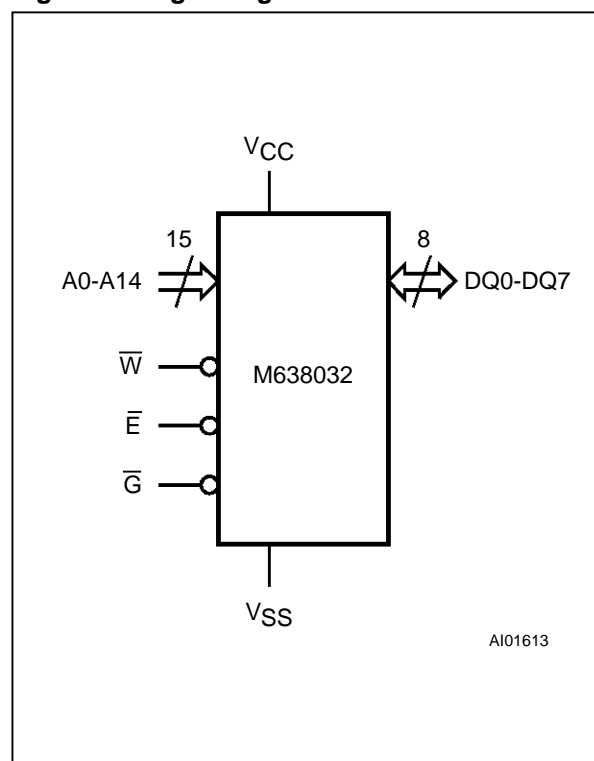

Table 2. Absolute Maximum Ratings ⁽¹⁾

Symbol	Parameter	Value	Unit
T _A	Ambient Operating Temperature	0 to 70	°C
T _{STG}	Storage Temperature	-65 to 150	°C
V _{IO} ⁽²⁾	Input or Output Voltages	-0.5 to V _{CC} + 0.5	V
V _{CC}	Supply Voltage	-0.5 to 4.6	V
I _O ⁽³⁾	Output Current	20	mA
P _D	Power Dissipation	1	W

Notes: 1. Except for the rating "Operating Temperature Range" stresses above those listed in the Table "Absolute Maximum Ratings" may cause permanent damage to the device. These are stress ratings only and operation of the device at these or any other conditions above those indicated in the Operating sections of this specification is not implied. Exposure to Absolute Maximum Ratings conditions for extended periods may affect device reliability. Refer also to the SGS-THOMSON SURE Program and other relevant quality documents.
 2. Up to a maximum operating V_{CC} of 3.6V only.
 3. One output at a time, not to exceed 1 second duration.

Table 3. Operating Modes

Mode	\bar{E}	\bar{W}	\bar{G}	DQ0-DQ7	Power
Read	V _{IL}	V _{IH}	V _{IH}	Hi-Z	Active
Read	V _{IL}	V _{IH}	V _{IL}	Data Output	Active
Write	V _{IL}	V _{IL}	X	Data Input	Active
Deselect	V _{IH}	X	X	Hi-Z	Standby

Note: X = V_{IH} or V_{IL}

Figure 2. SOJ Pin Connections

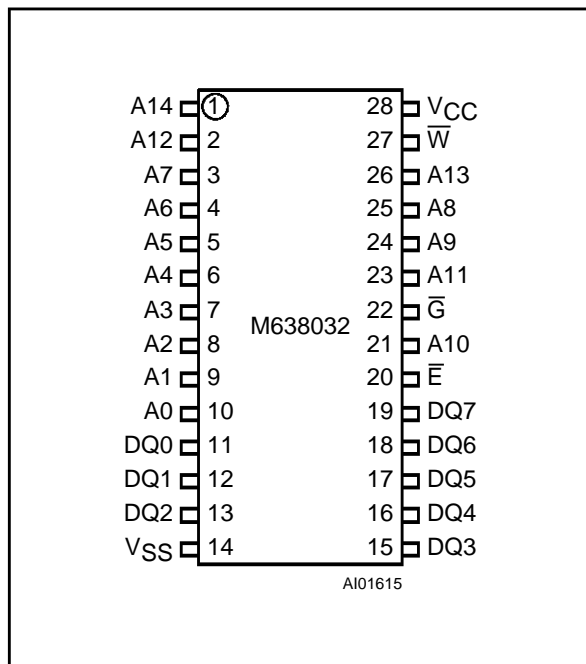

READ MODE

The M638032 is in the Read mode whenever Write Enable (\bar{W}) is High, with Output Enable \bar{G} Low, and Chip Enable (\bar{E}) asserted Low. This provides access to data from eight of the 262,144 locations in the static memory array, specified by the 15 address inputs. Valid data will be available at the eight output pins within t_{AVQV} after the last stable address, providing \bar{G} is Low, and Chip Enable \bar{E} is Low. If Chip Enable or Output Enable access times are not met, data access will be measured from the limiting parameter (t_{ELQV} or t_{GLQV}) rather than the address. Data out may be indeterminate at t_{ELQX} and t_{GLQX} , but datalines will always be valid at t_{AVQV} .

WRITE MODE

The M638032 is in the Write mode whenever the \bar{W} and \bar{E} pins are Low. Chip Enable input \bar{E} or the Write Enable input (\bar{W}) must be de-asserted during Address transitions for subsequent write cycles. Write begins with the concurrence of Chip Enable being active with \bar{W} Low. Therefore, address setup

Figure 3. Block Diagram

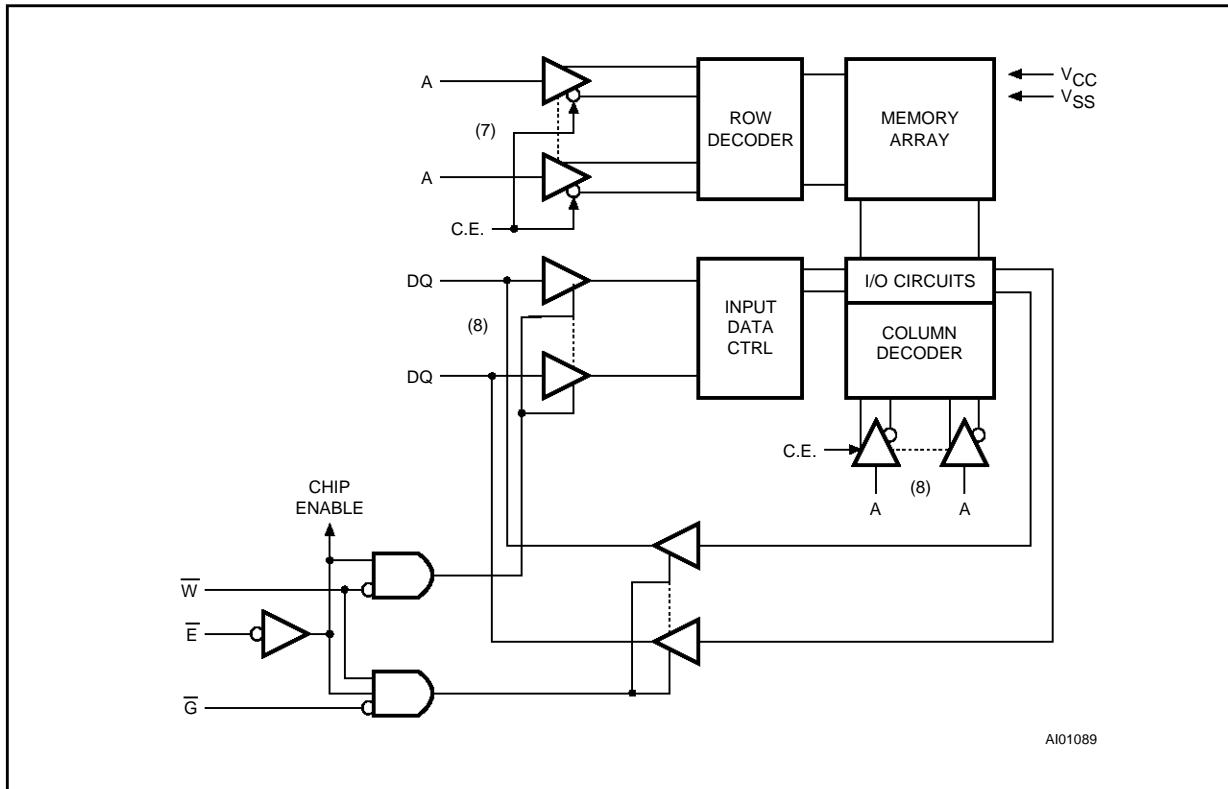

WRITE MODE (cont'd)

time is referenced to Write Enable and Chip Enable as t_{AVWL} and t_{AVEL} respectively, and is determined by the latter occurring edge. The Write cycle can be terminated by the earlier rising edge of \bar{E} or \bar{W} .

If the Output is enabled ($\bar{E} = \text{Low}$ and $\bar{G} = \text{Low}$), then \bar{W} will return the outputs to high impedance within t_{WLQZ} of its falling edge. Care must be taken to avoid bus contention in this type of operation. Data input must be valid for t_{DVWH} before the rising edge of Write Enable, or for t_{DVEH} before the rising edge of \bar{E} , whichever occurs first, and remain valid for t_{WHDX} or t_{HDX} .

OPERATIONAL MODE

The M638032 has a Chip Enable power down feature which invokes an automatic standby mode whenever Chip Enable is de-asserted ($\bar{E} = \text{High}$). An Output Enable (\bar{G}) pin provides a high speed tri-state control, allowing fast read/write cycles to be achieved with the common-I/O data bus. Operational modes are determined by device control inputs \bar{W} and \bar{E} as summarized in the Operating Modes table.

AC MEASUREMENT CONDITIONS

Input Rise and Fall Times	$\leq 1.5\text{ns}$
Input Pulse Voltages	0 to 3V
Input and Output Timing Ref. Voltages	1.5V

Note that Output Hi-Z is defined as the point where data is no longer driven.

Figure 4. AC Testing Load Circuit

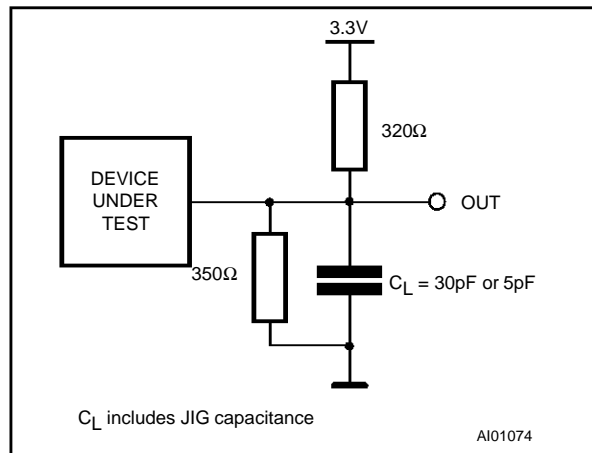

Table 4. Capacitance⁽¹⁾ ($T_A = 25\text{ °C}$, $f = 1\text{ MHz}$)

Symbol	Parameter	Test Condition	Min	Max	Unit
C_{IN}	Input Capacitance on all pins (except DQ)	$V_{IN} = 0V$		8	pF
C_{OUT} ⁽²⁾	Output Capacitance	$V_{OUT} = 0V$		9	pF

Notes: 1. Sampled only, not 100% tested
2. Outputs deselected

Table 5. DC Characteristics ($T_A = 0\text{ to }70\text{ °C}$, $V_{CC} = 3.3V \pm 0.3V$)

Symbol	Parameter	Test Condition	Min	Max	Unit
I_{LI}	Input Leakage Current	$0V \leq V_{IN} \leq V_{CC}$		± 1	μA
I_{LO}	Output Leakage Current	$0V \leq V_{OUT} \leq V_{CC}$		± 1	μA
I_{CC1} ⁽¹⁾	Supply Current	$V_{CC} = 3.6V, (-12)$		150	mA
		$V_{CC} = 3.6V, (-15)$		130	mA
		$V_{CC} = 3.6V, (-20)$		115	mA
I_{CC2} ⁽²⁾	Supply Current (Standby) TTL	$V_{CC} = 3.6V, \bar{E} = V_{IH}, f = 0$		25	mA
I_{CC3} ⁽³⁾	Supply Current (Standby) CMOS	$V_{CC} = 3.6V, \bar{E} \geq V_{CC} - 0.2V, f = 0$		1	mA
V_{IL}	Input Low Voltage		-0.3	0.8	V
V_{IH}	Input High Voltage		2.2	$V_{CC} + 0.3$	V
V_{OL}	Output Low Voltage	$I_{OL} = 8mA$		0.4	V
V_{OH}	Output High Voltage	$I_{OH} = -4mA$	2.4		V

Notes: 1. Average AC current, Outputs open, cycling at t_{AVAV} minimum
2. All other Inputs at $V_{IL} \leq 0.8V$ or $V_{IH} \geq 2.2V$
3. All other Inputs at $V_{IL} \leq 0.2V$ or $V_{IH} \geq V_{CC} - 0.2V$

Table 6. Read and Standby Modes AC Characteristics ($T_A = 0$ to 70°C , $V_{CC} = 3.3\text{V} \pm 0.3\text{V}$)

Symbol	Parameter	M638032						Unit
		-12		-15		-20		
		Min	Max	Min	Max	Min	Max	
t_{AVAV}	Read Cycle Time	12		15		20		ns
$t_{AVQV}^{(1)}$	Address Valid to Output Valid		12		15		20	ns
$t_{ELQV}^{(1)}$	Chip Enable Low to Output Valid		12		15		20	ns
$t_{GLQV}^{(1)}$	Output Enable Low to Output Valid		6		8		10	ns
$t_{ELQX}^{(2)}$	Chip Enable Low to Output Transition	3		3		3		ns
$t_{GLQX}^{(2)}$	Output Enable Low to Output Transition	0		0		0		ns
$t_{EHQZ}^{(2)}$	Chip Enable High to Output Hi-Z	0	5	0	8	0	10	ns
$t_{GHQZ}^{(2)}$	Output Enable High to Output Hi-Z	0	5	0	8	0	10	ns
$t_{AXQX}^{(1)}$	Address Transition to Output Transition	3		3		3		ns
$t_{PU}^{(3)}$	Chip Enable to Power Up	0		0		0		ns
$t_{PD}^{(3)}$	Chip Enable to Power Down		12		15		20	ns

Notes: 1. $C_L = 30\text{pF}$ (see Figure 4)
 2. $C_L = 5\text{pF}$ (see Figure 4)
 3. Guaranteed but not tested (see Figure 7)

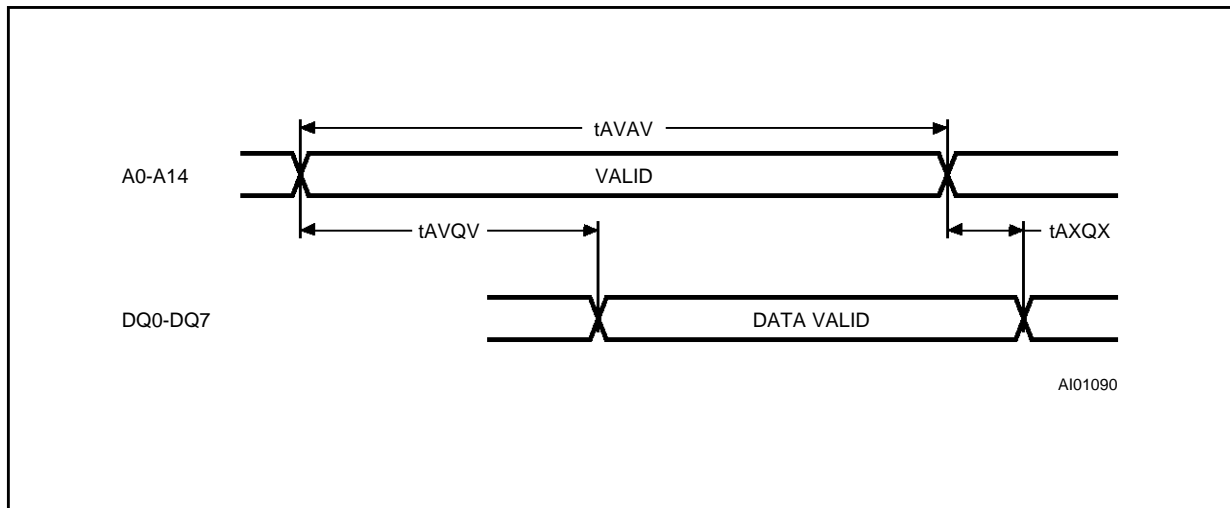
Figure 5. Address Controlled, Read Mode AC Waveforms

Note: \bar{E} = Low, \bar{G} = Low, \bar{W} = High

Figure 6. Chip Enable or Output Enable Controlled, Read Mode AC Waveforms

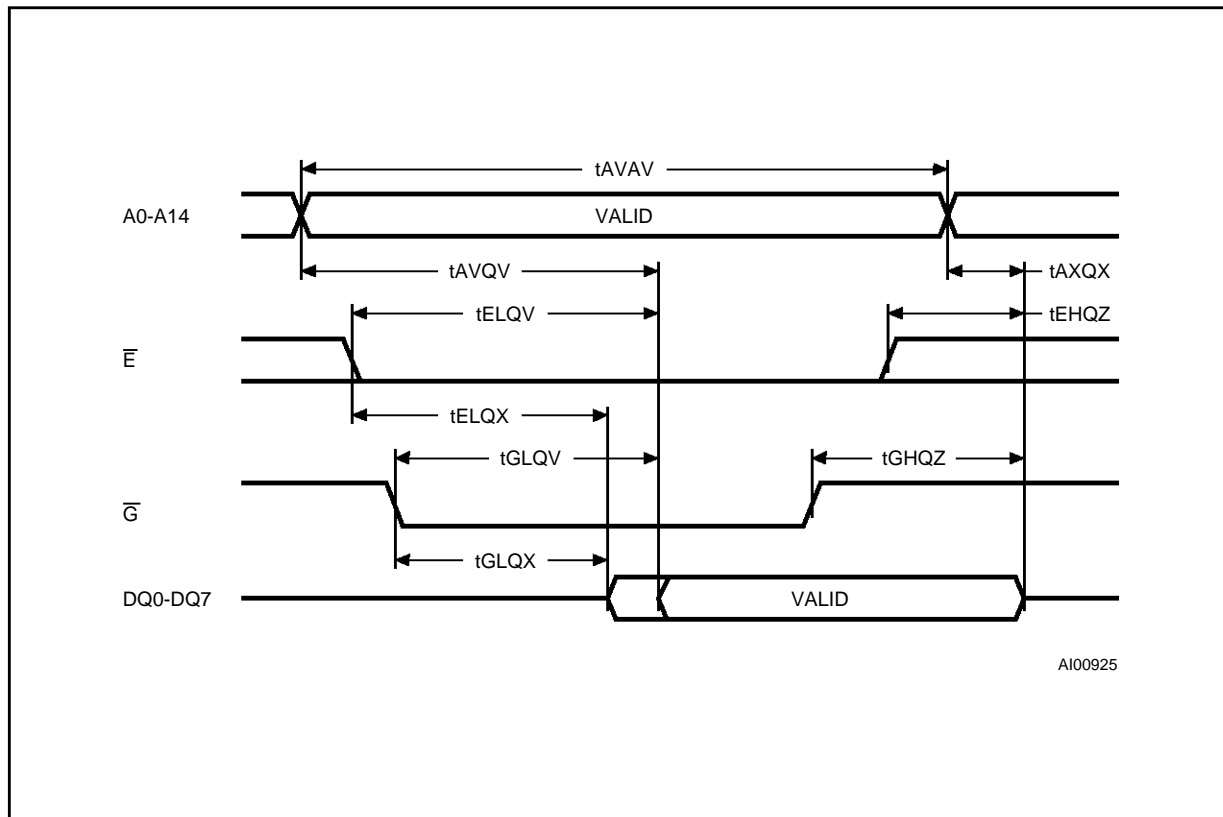

Note: Write Enable (\bar{W}) = High

Figure 7. Standby Mode AC Waveforms

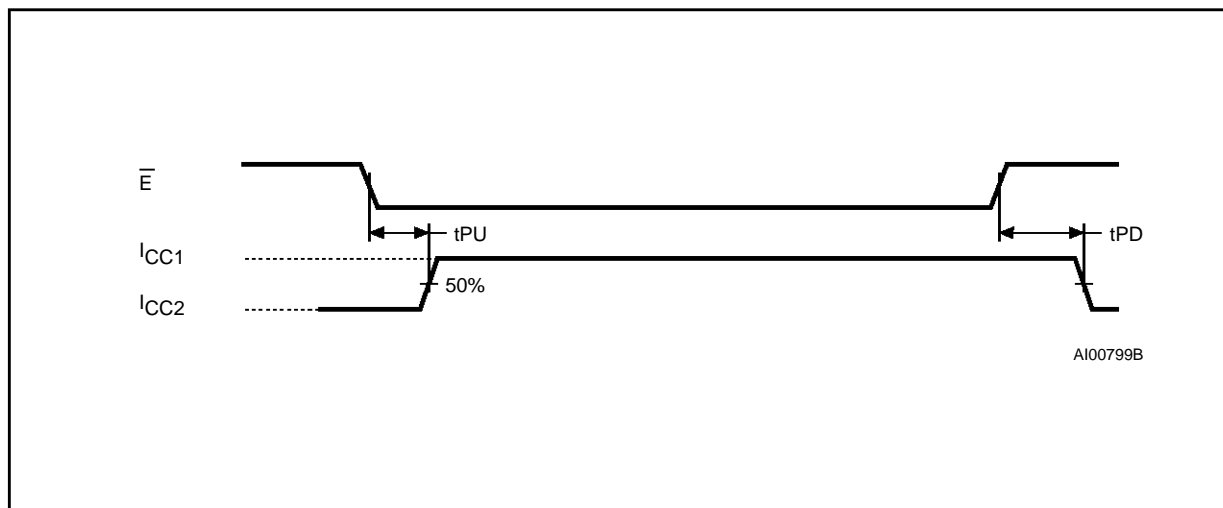
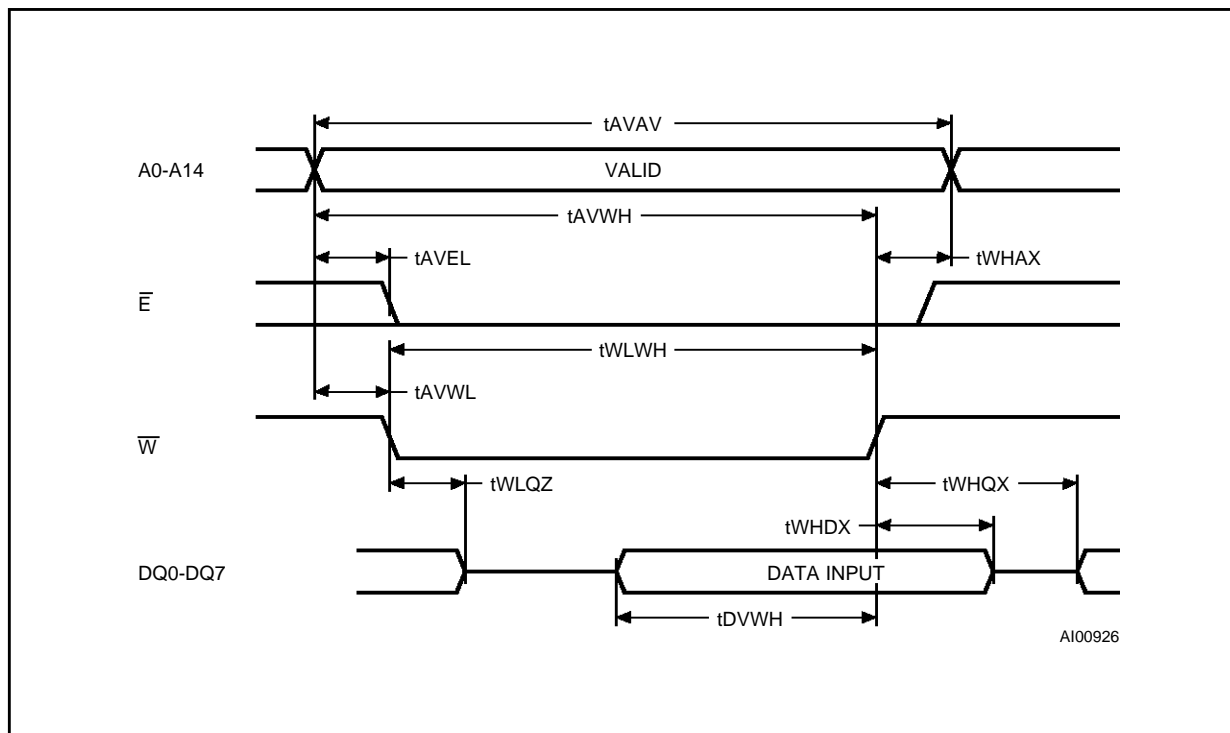

Table 7. Write Mode AC Characteristics ($T_A = 0$ to 70°C , $V_{CC} = 3.3\text{V} \pm 0.3\text{V}$)

Symbol	Parameter	M638032						Unit
		-12		-15		-20		
		Min	Max	Min	Max	Min	Max	
t_{AVAV}	Write Cycle Time	12		15		20		ns
t_{AVWL}	Address Valid to Write Enable Low	0		0		0		ns
t_{AVWH}	Address Valid to Write Enable High	10		10		12		ns
t_{AVEH}	Address Valid to Chip Enable High	10		10		12		ns
t_{WLWH}	Write Enable Pulse Width	8		10		12		ns
t_{WHAX}	Write Enable High to Address Transition	0		0		0		ns
t_{WHDX}	Write Enable High to Input Transition	0		0		0		ns
t_{EHDX}	Chip Enable High to Input Transition	0		0		0		ns
$t_{WHQX}^{(1)}$	Write Enable High to Output Transition	3		3		3		ns
$t_{WLQZ}^{(1)}$	Write Enable Low to Output Hi-Z	0	6	0	8	0	10	ns
t_{AVEL}	Address Valid to Chip Enable Low	0		0		0		ns
t_{ELEH}	Chip Enable Low to Chip Enable High	10		10		12		ns
t_{EHAX}	Chip Enable High to Address Transition	0		0		0		ns
t_{DVWH}	Input Valid to Write Enable High	6		8		10		ns
t_{DVEH}	Input Valid to Chip Enable High	6		8		10		ns

Note: 1. $C_L = 5\text{pF}$ (see Figure 4)

Figure 8. Write Enable Controlled, Write AC Waveforms

Note: Output Enable (\bar{G}) = Low

Figure 9. Chip Enable Controlled, Write AC Waveforms

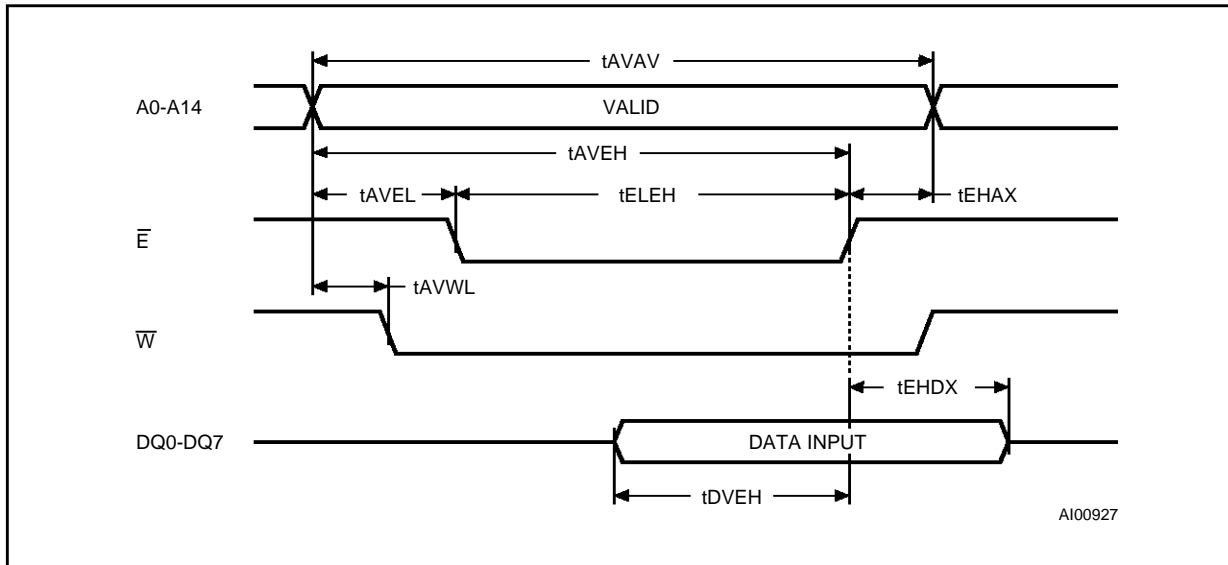

Note: Output Enable (\bar{G}) = High

Table 8. Low V_{CC} Data Retention Characteristics ($T_A = 0$ to 70°C , $V_{CC} = 2\text{V}$ to 3V)

Symbol	Parameter	Test Condition	Min	Max	Unit
$I_{CCDR}^{(1)}$	Supply Current (Data Retention)	$V_{CC} = 2\text{V}, \bar{E} \geq V_{CC} - 0.2\text{V}, f = 0$		150	μA
$V_{DR}^{(1)}$	Supply Voltage (Data Retention)	$\bar{E} \geq V_{CC} - 0.2\text{V}, f = 0$	2	3	V
$t_{CDR}^{(1,2)}$	Chip Disable to Power Down	$\bar{E} \geq V_{CC} - 0.2\text{V}, f = 0$	0		ns
$t_R^{(2)}$	Operation Recovery Time			t_{AVAV}	ns

Notes: 1. All other Inputs $V_{IH} \geq V_{CC} - 0.2\text{V}$ or $V_{IL} \leq 0.2\text{V}$
 2. See Figure 10 for measurement points. Guaranteed but not tested

Figure 10. Low V_{CC} Data Retention AC Waveforms

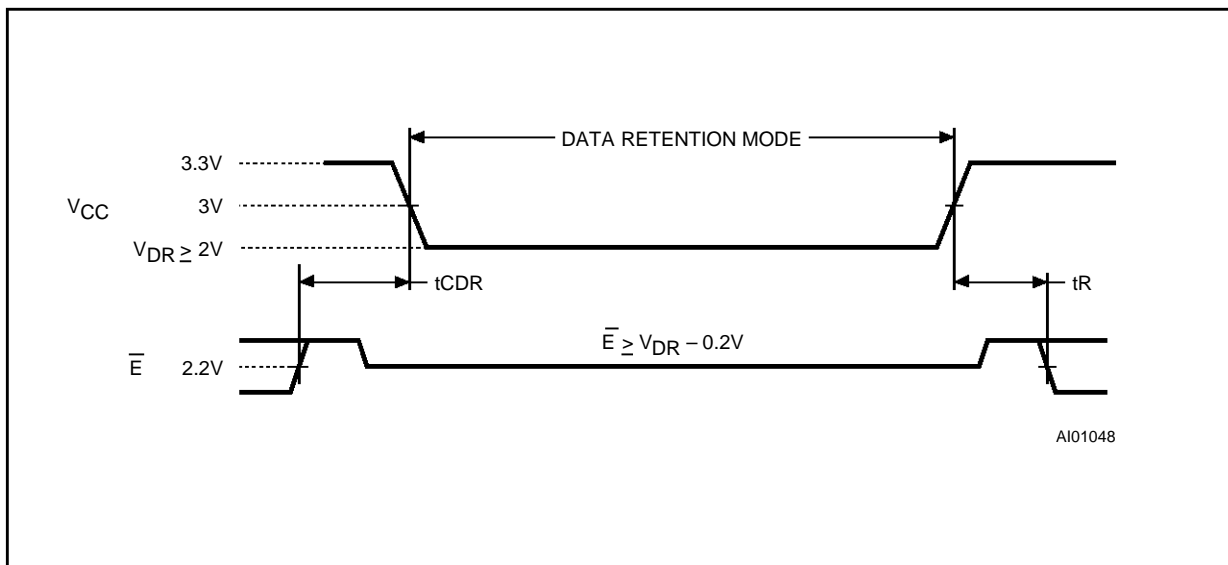

ORDERING INFORMATION SCHEME

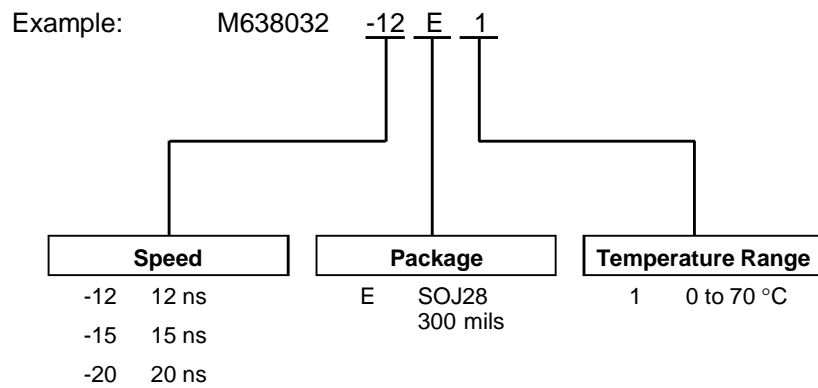

For a list of available options (Speed, Package, etc...) refer to the current Memory Shortform catalogue.
For further information on any aspect of this device, please contact the SGS-THOMSON Sales Office nearest to you.

SOJ28 - 28 lead Plastic Small Outline J-lead, 300 mils

Symb	mm			inches		
	Typ	Min	Max	Typ	Min	Max
A		3.05	3.56		0.120	0.140
A1		0.71	0.91		0.028	0.036
A2		2.29	2.39		0.090	0.094
B		0.36	0.48		0.014	0.019
D		17.81	18.06		0.701	0.711
E		7.42	7.59		0.292	0.299
e	1.27	-	-	0.050	-	-
eA		6.65	6.91		0.262	0.272
H		8.51	8.81		0.335	0.347
N	28			28		
CP			0.10			0.004

SOJ28

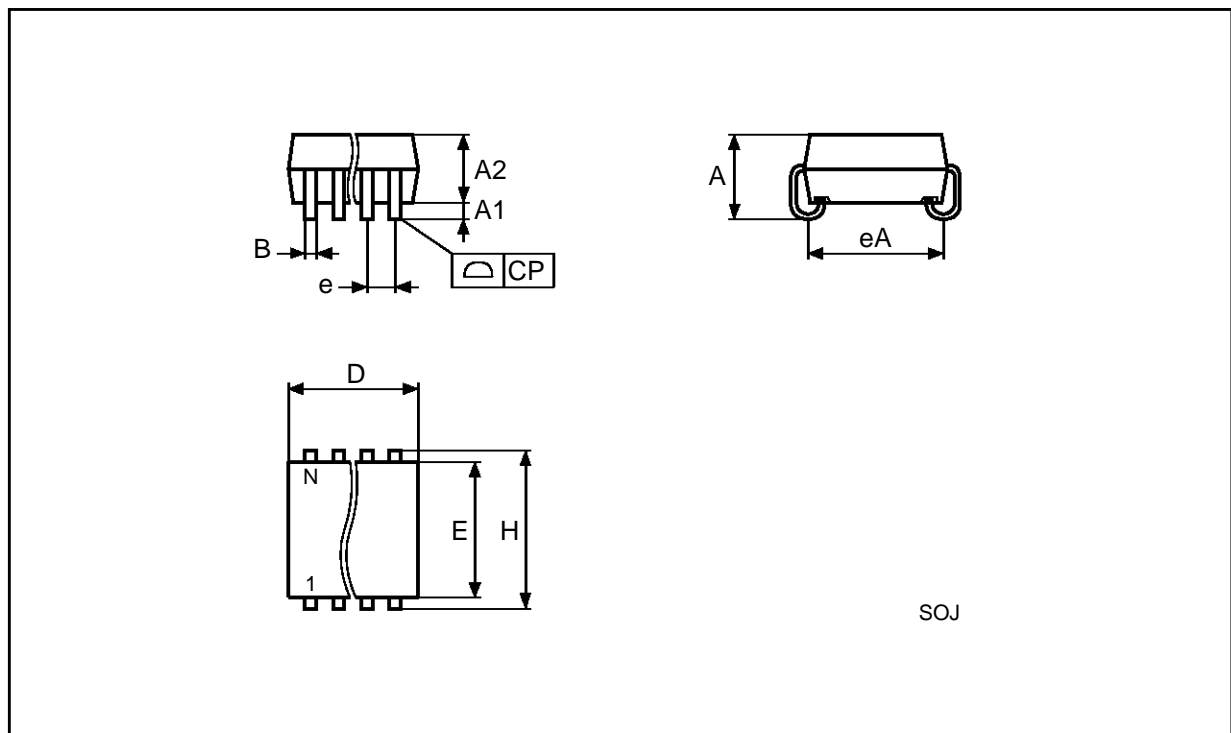

Drawing is not to scale

Information furnished is believed to be accurate and reliable. However, SGS-THOMSON Microelectronics assumes no responsibility for the consequences of use of such information nor for any infringement of patents or other rights of third parties which may result from its use. No license is granted by implication or otherwise under any patent or patent rights of SGS-THOMSON Microelectronics. Specifications mentioned in this publication are subject to change without notice. This publication supersedes and replaces all information previously supplied. SGS-THOMSON Microelectronics products are not authorized for use as critical components in life support devices or systems without express written approval of SGS-THOMSON Microelectronics.

© 1995 SGS-THOMSON Microelectronics - All Rights Reserved

SGS-THOMSON Microelectronics GROUP OF COMPANIES
Australia - Brazil - Canada - China - France - Germany - Hong Kong - Italy - Japan - Korea - Malaysia - Malta - Morocco - The Netherlands -
Singapore - Spain - Sweden - Switzerland - Taiwan - Thailand - United Kingdom - U.S.A.